

Components for Surface Analysis

JT-STM

Joule-Thomson Scanning Tunneling Microscope

Key Features

- Base Temperature: < 1 K
(Optional < 500 mK)
- Temperature Range: 1 K - 400 K
- LHe Hold Time: > 4 days
- Extreme Stability
- Nanonis Control System
- Magnetic Field up to 3 Tesla

Applications

- Inelastic Electron Tunneling Spectroscopy
- Investigation of Superconductors
- Quantum Structures
- Spin Polarized Tunneling
- Atomic Manipulation
- Molecular Electronics
- Customized Systems

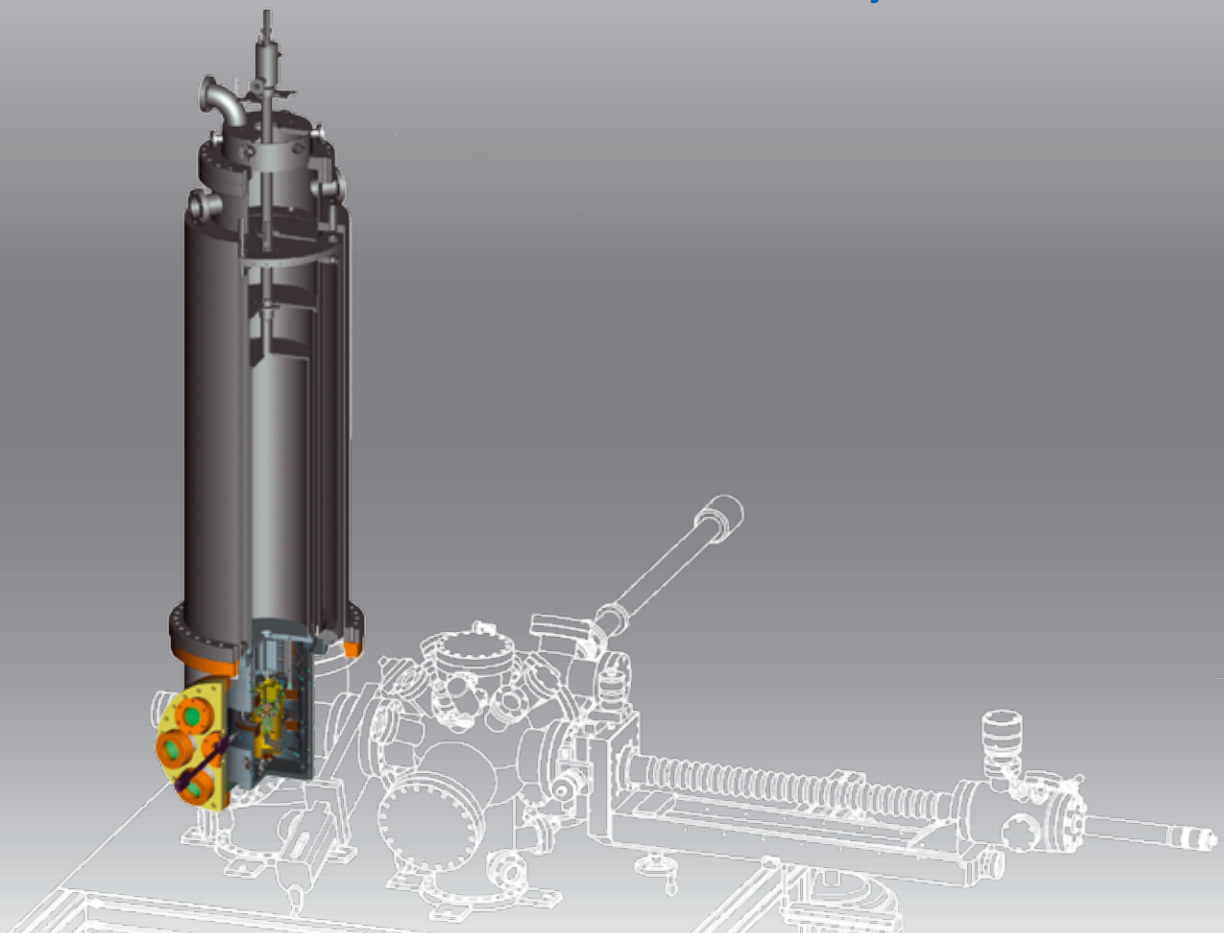

The JT-STM marks SPECS latest significant achievement in UHV scanning probe microscopy – simple handling, unprecedented stability, and an extremely long operating time without interruption.

Joule-Thomson Cryostat

The cryostat was designed by Prof. W. Wulfhekel and is based on a Joule-Thomson cooling stage. The stage is mounted below the LHe bath cryostat with vapor-cooled shields and a surrounding LN2 vessel, all inside the UHV chamber. The consumption of LHe and LN2 in the cryostat is extremely low. This reduces cost and vibrations and allows for uninterrupted experiments to be run over more than 4 days.

Highest Resolution and Stability

The STM is extremely stable mechanically at all temperatures and allows positioning of the tip above an atom for extended periods. The thermal broadening of the Fermi edge is reduced significantly compared with what is typically observed at 4 K. The JT-STM in conjunction with the Nanonis control system exploits both of these advantages to the full, and is therefore especially suited to all kinds of tunneling spectroscopy experiments.

STM Head

The STM head is based on a proven design and optimized for highest thermal and mechanical stability. The coarse positioning of the tip in the Z-direction and the sample in one lateral direction is made with highly rigid piezo motors on sapphire sliding surfaces. Special care has been taken to ensure thermal equilibrium of all microscope parts, even at the lowest temperatures. This results in almost drift-free tip positioning. The reliable piezo motors facilitate tip exchange by means of a special carrier transfer plate, using the keyhole principle. Windows in the radiation shield allow for in-situ evaporation and visual alignment of the tip and sample with an optical microscope.

³He Upgrade Option

The Joule-Thomson stage can also be operated with ³He. This option can be installed without modifying the UHV system. About 10 liters of ³He gas are pumped in a closed cycle. With ³He the temperature can be reduced to below 500 mK.



Magnet Upgrade Option

A superconducting magnet can be mounted to order or added later. Magnetic fields up to 3 Tesla normal to the sample can be applied. The split coil magnet is mounted in UHV on the 4K radiation shield. A precision power supply ensures automated and safe operation. The magnet power supply is fully integrated into the LabVIEW™ Programming environment for maximum flexibility in experiment automation.

JT-Kolibri: AFM Upgrade with KolibriSensor®

SPECS is currently developing an option to upgrade the JT-STM for non-contact AFM at sub-ångström amplitudes based on KolibriSensor® technology. The KolibriSensor® features a separately contacted metallic tip for STM mode scanning and electrical tip access in nc-AFM mode (see separate catalogue).

Nanonis Control System

The Nanonis Control System offers the highest resolution, lowest noise and the greatest flexibility. It is the most reliable control system for the long duration automated experiments that are possible with the JT-STM.

SPECS UHV System Integration

For a seamlessly integrated system, SPECS offers the complete range of UHV components in addition to our expertise and service. Unique solutions for sample preparation, manipulation and surface analysis are tailored to your needs.

Support & Customization

Installation, on-site training and support are important factors for obtaining fast results and short time to publication. The team of SPM application experts at SPECS has extensive experience in both SPM technology and SPM science. The modern design and production infrastructure at SPECS allow for efficient implementation of customized solutions.

Specification	Guaranteed	Achievable
Base temperature ⁴ He Joule-Thomson	1.5 K	900 mK
Base temperature ³ He Joule-Thomson	900 mK	500 mK
Hold time (T < 1.5 K)	4 days	6 days
Liquid helium consumption	0.1 l/h	0.06 l/h
Magnetic field (out-of-plane)	3 T	
Drift	< 200 pm/h	20 pm/h
Optical microscope resolution	15 µm	10 µm
X-travel range	± 2 mm	± 2.5 mm
Z-travel range	10 mm	
XY-scan (300 K/77 K/< 5 K)	5/1.5/1 µm	Option: 3.5 µm@5K
Z-scan (300 K/77 K/< 5 K)	700/200/ 100 nm	
Preamplifier noise floor (FEMTO)	5 fA / √Hz	
Minimum tunneling current setpoint	0.5 pA	

Technical alterations reserved. The information in this document is provided with greatest care but SPECS does not assume any liability arising from the application or use of the information or product described here. SPECS and KolibriSensor are a registered trademarks

of SPECS GmbH. Other product and company names mentioned herein are trademarks or trade names of their respective companies.
Printed in February 2010

SPECS Surface Nano Analysis GmbH
Voltastrasse 5
13355 Berlin
Germany

Tel.: +49 30 46 78 24-0
Fax: +49 30 46 42 08-3
Email: support@specs.com
Web: www.specs.com



ISO 9001 Certificate

Your Local Representative: